

# TECHNICAL DATA

SINGLE DRUM ROLLER

BW 211 D-5 SL, BW 211 PD-5 SL

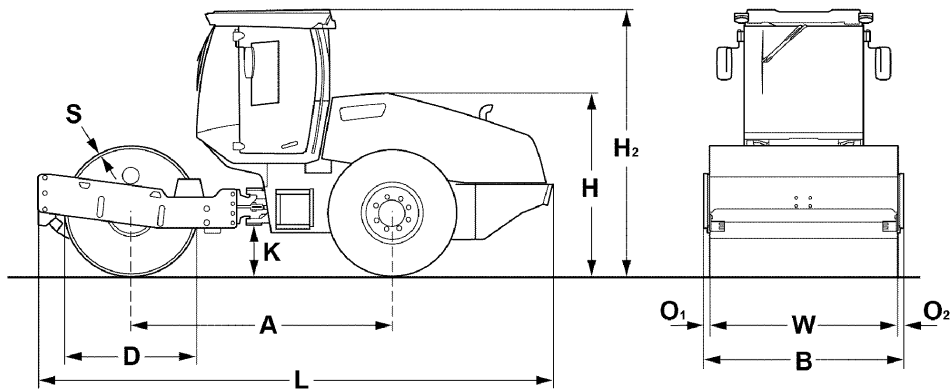



**Dimensions in mm**

	A	B	D	H	H2	K	L	O1	O2	S	W
BW 211 D-5 SL	2975	2260	1500	2240	3053	530	5870	65	65	25	2130
BW 211 PD-5 SL	2975	2260	1480	2240	3053	530	5870	65	65	25	2130

**Shipping dimensions in m3**

BW 211 D-5 SL  
 BW 211 PD-5 SL

**without ROPS**

29,716  
 29,716

**with ROPS**

40,502  
 40,502

Machine type	Compaction output (m3/h)			
	Rock fill	Gravel, sand	Mixed soil	Silt, clay
BW 211 D-5 SL	400-800	270-540	220-440	110-220
BW 211 PD-5 SL	400-800	270-540	220-440	160-220

Machine type	Compacted layer thickness (m)			
	Rock fill	Gravel, sand	Mixed soil	Silt, clay
BW 211 D-5 SL	0,70	0,50	0,40	0,20
BW 211 PD-5 SL	0,70	0,50	0,40	0,25

**Technical Data****BOMAG  
BW 211 D-5 SL****BOMAG  
BW 211 PD-5 SL****Weights**

Grossweight .....	kg	13.290	12.330
Operating weight .....	kg	10.120	11.670
Operating weight CECE w. ROPS-cabin .....	kg	10.630	12.180
Axle load, drum CECE .....	kg	6.040	7.590
Axle load, wheels CECE .....	kg	4.590	4.590
Static linear load CECE .....	kg/cm	28,4	

**Dimensions**

Working width .....	mm	2.130	2.130
Track radius, inner .....	mm	3.677	3.677

**Driving Characteristics**

Speed (1) .....	km/h	0- 6,0	0- 6,0
Speed (2) .....	km/h	0- 10,0	0- 11,5
Max. gradeability without/with vibr. ....	%	45/43	45/43

**Drive**

Engine manufacturer .....		Cummins	Cummins
Type .....		4 BTAA 3.9	4 BTAA 3.9
Cooling .....		water	water
Number of cylinders .....		4	4
Performance ISO 3046 .....	kW	82,0	82,0
Performance SAE J 1995 .....	hp	110,0	110,0
Speed .....	min-1	2.200	2.200
Fuel .....		Diesel	Diesel
Electric equipment .....	V	12	12
Drive system .....		hydrost.	hydrost.
Drum driven .....		standard	standard

**Drums and Tyres**

Tyre size .....		23.1-26/12PR	23.1-26/12PR
Number of pad feet .....			150
Area of one pad foot .....	cm <sup>2</sup>		137
Height of pad feet .....	mm		100

**Brakes**

Service brake .....		hydrost.	hydrost.
Parking brake .....		hydromec.	hydromec.

**Steering**

Steering system .....		oscil.artic.	oscil.artic.
Steering method .....		hydrost.	hydrost.
Steering / oscillating angle +/- .....	grad	35/12	35/12

**Exciter system**

Drive system .....		hydrost.	hydrost.
Frequency .....	Hz	30/36	30/36
Amplitude .....	mm	1,80/0,95	1,70/0,86
Centrifugal force .....	kN	236/170	275/202
Centrifugal force .....	t	24,1/17,3	28,1/20,6

**Capacities**

Fuel .....	l	250,0	250,0
------------	---	-------	-------

Technical modifications reserved. Machines may be shown with options.

### Standard Equipment

- Hydrostatic travel and vibration drive
- Self locking differential
- Warning horn
- Single lever control for travel and vibration
- Hydrostatic articulated steering
- Emergency STOP
- Scraper
- Back-up warning system
- Operator seat
- Maintenance-free articulated joint

### Optional Equipment

- Railing
- Sun roof
- ROPS/FOPS with safety belt
- ROPS/FOPS-cabin with heating
  - +Seat belt
- ROPS/FOPS-cabin with heating
  - +Air condition
- Working lights front / rear
- Rotary beacon
- Mirror
- Road lights
- Padfoot segment kit
- Contact scrapers (2x)
- 2 scrapers per drum
- ECONOMIZER
- Special painting
- Radio (Bluetooth)
- BOMAP
- Terrameter
- Tachograph

